

Installation Instructions for SBL350 Push Button Lock with Key Override

This lock has been Fire Tested in accordance with BS EN1634-1 with the use of Intumescent Seals.

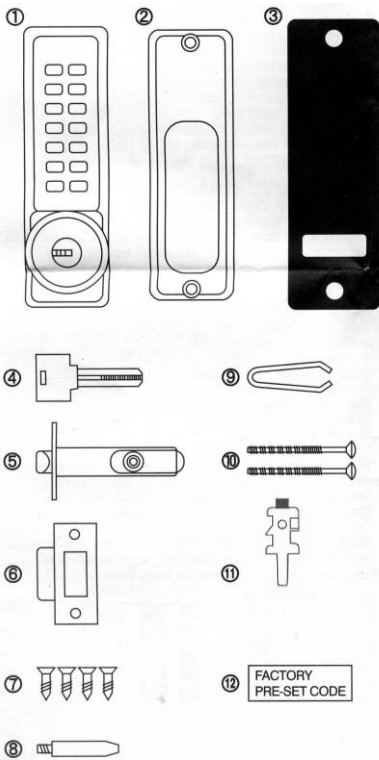

LIST OF PARTS

- 1) Digital Lock with Key Override
- 2) Internal Block
- 3) Neoprene Seals x 2
- 4) Keys x 3
- 5) Latch (60mm standard)
- 6) Striker Plate
- 7) Wood screws x 4 (For securing Latch and Striker Plate)
- 8) Bolt Guide
- 9) Tweezers (For changing the Code)
- 10) Fixing Bolts x 3 (1 spare)
- 11) Spare Code Tumblers
- 12) Code Card

BEFORE INSTALLATION PLEASE:

- 1) Ensure all parts work properly
- 2) Check and Ensure the supplied Code works. If you wish to change the code follow the instructions under 'Changing the Code' and confirm at it works.
- 3) Ensure that both knob handles of the Digital Lock can be moved freely. Check that the Hold Back function can be engaged and keeps the latch retracted and handle pressed. Also check that the latch moves freely by pressing the end and by turning with the spindle

Installation

Applying the Template

- Correctly position and tape the template, T/035/SBL300, to the internal door face, at the desired height from the floor level. Ensure that the relevant, marked, door edge on template is correctly aligned with actual door edge. (Figure 1)
- Mark the 10mm diameter hole for the spindle of the Digital Lock, the two 7mm holes for the bolt through fixings.
- Mark the correct 6mm diameter hole, for the reinforcement pin, depending on the handing of the door.
- Drill all marked holes.

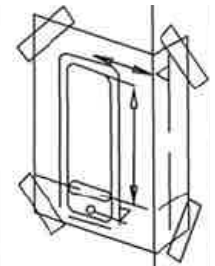

Figure 1

Handing Digital Lock

IMPORTANT: Firstly determine handing of the door. When viewed from the outside, your door is right handed if the hinges are on the right and left handed if the hinges are on left.

NOTE: The Knob on the external Keypad Digital Lock will rotate freely in one direction and require the inputting of the code to rotate in the other direction; this allows the deadbolt to be thrown from the outside without a code entry but not withdrawn.

- Remove the cover held in place by 2 blue screws.
- With Tweezers remove the metal pin and put in the other visible hole to change handing.
- Replace cover and secure using blue screws.

The metal pin will only locate in the back of the digital lock unit properly if the follower is in the correct orientation (as shown in the images on the right).

If you do not reinsert the metal pin in to either of the holes then the deadbolt can be thrown and withdrawn from the outside without the entry of a correct code.

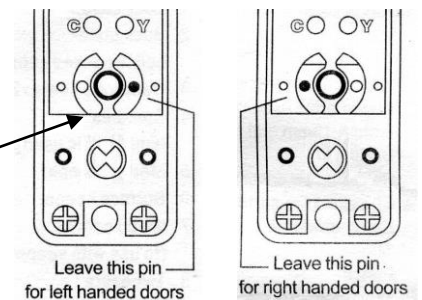

Applying the Intumescent Seals

IMPORTANT: In order for this unit to maintain its fire rating status and be suitable to be installed on a fire rated door Intumescent Seals **must** be used. A 2mm self-adhesive **mono-ammonium phosphate (Interdens)** intumescent seal is recommended.

- Using the intumescent seal wrap the barrel of the tubular latch in one uniform layer
- Affix one 2mm intumescent layer behind forend of latch and behind the rear of the striker prior to installation.

Installing the Latch

- Mark a central point on the 'centre line of latch' across the thickness of the door. (Figure 2)
- At the marked position drill a 25mm diameter hole x 80mm deep
- Inset Latch into the hole and draw around the face plate.
- Remove latch and cut a 5mm rebate to allow the Latch face plate to sit flush in the door.
- Secure latch with wood fixing screws ensuring the positioning is square.

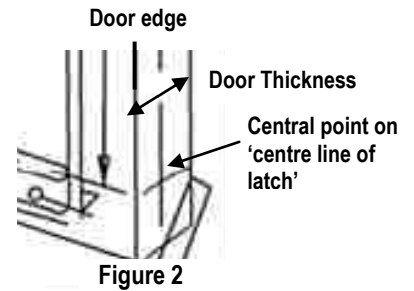

Installation of Reinforcement Pin

- Screw the Bolt Guide in to Hole A (Figure 3) for a door opening to the (clockwise opening)
- Screw the Bolt Guide in to Hole B (Figure 3) for a door opening to the left (anti-clockwise opening)
- The guide will locate in Hole 'O' of the Latch to help maintain positioning. (Figure 3b)

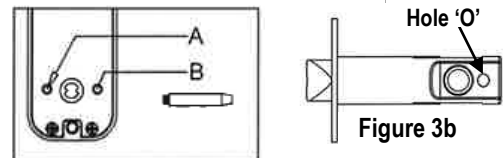

Positioning of Spindle

- The spindle is designed for doors 35 to 65 mm thick. Therefore shorten, if necessary, to suit door thickness
- When inserting the spindle correctly locate it into the reverse of the Internal Block with consideration to the handing of the door. (Figure 4)

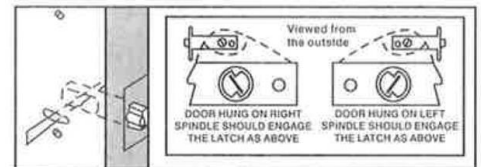

Fixing the Lock

IMPORTANT: Do not close the door before confirming that the code and lock is functioning correctly.

- If necessary, shorten the fixing bolts in order to suit the thickness of the door
- When shortening the fixing bolts allow at least 4/5 threads to screw into the lock case
- Locate the rubber seal behind the Digital Lock and using the fixing bolts secure the top and bottom of the Lock to the door.
- Before final tightening ensure the Lock is vertical and test mechanism to ensure that it is moving freely.
- Do not excessively tighten the Lock and seals to the door as it could damage the operation of the mechanism.

Fixing Striker Plate

IMPORTANT: The striker must be positioned so that only the latch itself can enter the aperture and the anti-thrust must stop on the striker plate itself to maintain its anti-burglar function when the door is locked.

- Correctly position the striker plate, taking the above into consideration.
- Once the correct position is determined draw around the striker plate and mark the two holes.
- Remove the striker and cut a 1mm rebate to allow the striker to sit flush within the door frame.
- If necessary drill or cut a recess, at the correct position of the striker, for the latch to enter when the door is closed.
- Drill the two, marked, holes for securing striker
- Fix the striker with one screw first. Test the Lock to see if it works and is latching and locking correctly. If not proceed with any necessary adjustments before securing completely
- If no adjustments are to be made completely secure striker with second screw.

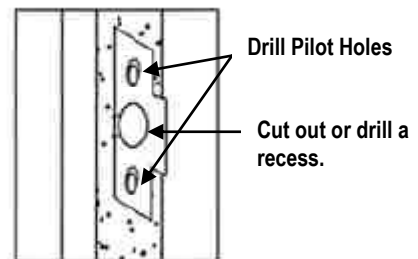
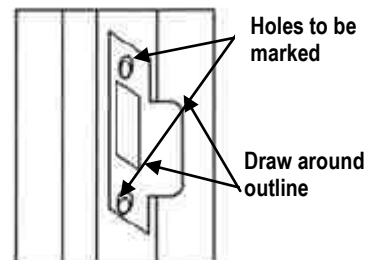

Changing the Code

IMPORTANT: Keep the Lock on a flat surface at all times when removing the plate to gain access as there are a lot of small components inside. You should NEVER remove the 'C' tumbler.

- On the reverse of the Digital Lock remove the 4 screws retaining the metal plate.
- There are 5 Red Keyed tumblers, 8 Blue Keyless tumblers and 1 Clear tumbler ('C' Button).

NOTE: With the spare tumblers you can either increase the number of digits in the code to 6 or 7 or decrease to 3.

- Press the 'C' button and hold it at all times during the process; using the tweezers you can remove one or more of the keyed & keyless tumblers.
- Re-insert the tumblers (putting the Blue tumblers in the slots corresponding with the buttons you do not wish to use and the Red in those you do wish to use) to produce the desired code.

NOTE: The keyed and keyless tumblers vary in shape therefore it is essential that they are reinserted in the correct orientation as shown below in Figure 5.

- Once the tumblers are refitted make a note of the new code and replace and secure the metal plate with the 4 screws. Check the code functions before refitting to the door.

