

### SBL365 Mechanical Digital Locks with Latch

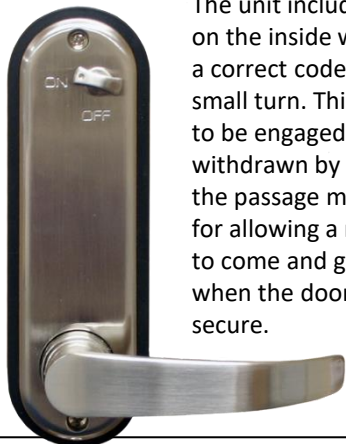

The unit includes a “Passage Mode” on the inside which is activated once a correct code is entered by turning a small turn. This allows the latch bolt to be engaged in the striker, but is withdrawn by either lever handle until the passage mode is released. Ideal for allowing a non-authorized person to come and go through the door when the door does not need to be secure.

***The Easy Code SBL365 range is lever operated and has been designed to simplify the code changing process by eliminating the need to move retainers around in the mechanism.***

The SBL365 range of fire rated mechanical digital locks has been tested to EN1634-1 for use on 30 min. and 60 min. fire doors.

Intumescent fitted to the latch is essential for use in fire doors creating additional protection to the door’s overall performance.

The Securefast intumescent fire door seal is supplied around the tubular latch for a quicker, easier, cleaner and accurate solution on Securefast mechanical digital locks. To complete the package seals are provided for behind the striker.

#### Features & Benefits

- Supplied with tubular latch
- >800 Non-sequential code combinations
- Tested to EN12209
- These units have “Easy Code” change
- Suitable for external use having completed 240hr salt spray test to EN1670
- Suitable for timber and steel doors 35-65mm thick
- Compact and robust zinc diecast body
- Free passage mode
- Supplied with black neoprene seals
- The SBL365 mechanical digital lock range has been certified to EN1634-1 for use on 30 min. and 60 min. timber fire doors by Exova Warrington

Mechanical digital locks are used extensively in hospitals, schools, universities etc. on fire doors, therefore it is important that the integrity of the door is not compromised by failing to include the intumescent seals.



Fire-rated mechanical digital locks are supplied complete with intumescent attached ready for installation.

### SBL365 Mechanical Digital Locks with Latch

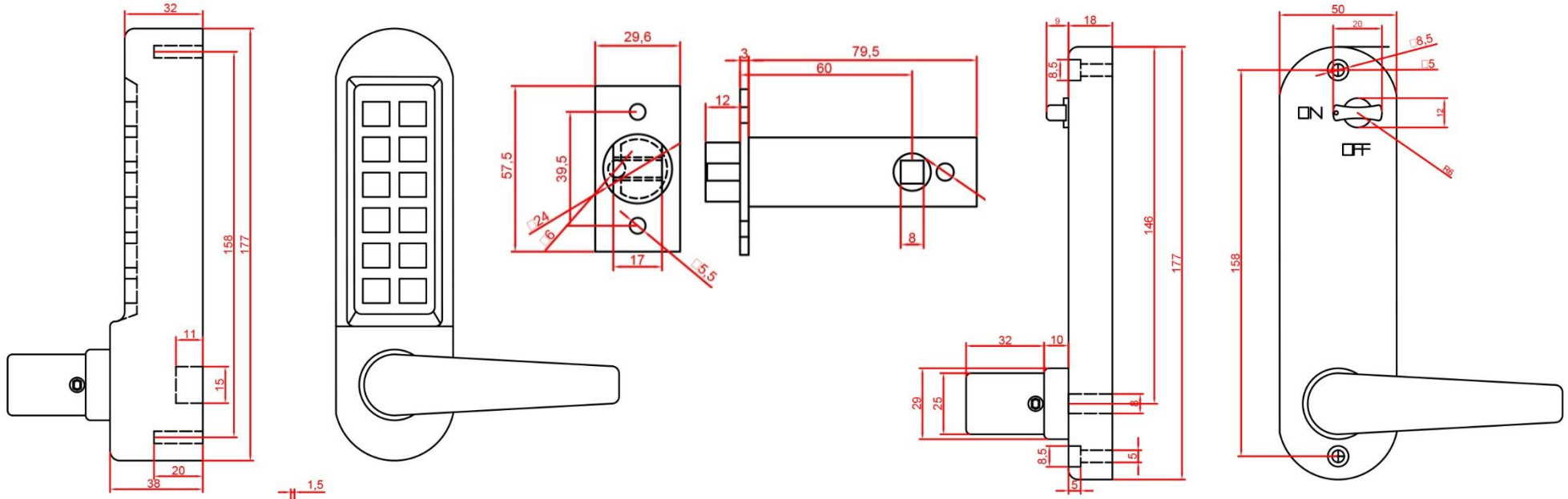

Product Code	Description	Fire Rated	Finish	Available Code Buttons	No. Digits per Code	Dimensions (mm)			Fixing Centres
						Height	Width	Depth	
SBL365.S	Standard with Lever & Passage Mode		Satin Chrome	11	1-11	178	48	90	158
SBL365.SFR	Standard with Lever & Passage Mode	●	Satin Chrome	11	1-11	178	48	90	158

For further information contact:

**Securefast plc**  
 6, The Cedars Business Centre  
 Avon Road, Cannock  
 Staffordshire  
 WS11 1QJ



**Call** > +44 (0) 1704 502 801

**Email** > sales@securefast.co.uk

**Visit** > www.securefast.co.uk