

## SBL350.S & SBL350.SFR Mechanical Digital Push Button Lock with Key Override



*The SBL350 is a compact and self contained mechanical digital coded lock with a knob and key override, supplied complete with a 60mm backset deadlocking tubular latch.*

The digital lock is robust and gives a convenient means of providing security for low to medium traffic areas such as storerooms, workshops, plant rooms and offices.

The SBL350 allows entry either via the code or with one of the keys supplied with the unit. The internal unit provides safe egress by a large turn knob.

The SBL350.SFR is fire rated for use on 30 min and 60 min timber fire doors and is supplied with the intumescent fixed ready for fitting to the door.

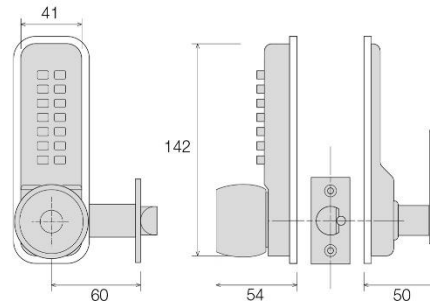

Product Code	Description
SBL350.S	Push Button lock with key override
SBL350.SFR	Fire Rated Push Button lock with key override

### Features & Benefits

- Supplied with 60mm backset deadlocking tubular latch
- Key override feature to gain access in an emergency or as an alternative to code entry
- Suitable for external use having completed 240hr salt spray test to EN1670
- Internal unit provides egress by a large turn knob
- Hold back function on internal unit allows unrestricted access
- Suitable for timber doors 35 - 65mm thick
- Compact and robust zinc die cast body
- Supplied with 3 no. standard differ keys
- Supplied with black neoprene seals
- Performance tested to EN12209
- Fire rate tested for use on 30 min and 60 min timber fire doors

For further information contact:

**Securefast plc**  
 6, The Cedars Business Centre  
 Avon Road, Cannock  
 Staffordshire  
 WS11 1QJ



**Call** > +44 (0) 1704 502 801

**Email** > sales@securefast.co.uk

**Visit** > www.securefast.co.uk