

AML-350M-PL-12 & AML350M-PL-24 Electric Lock with Preload



Securefast mortice double action electric locks are a high performance lock for use with swing doors and single action doors

The lock has a robust stainless steel construction and is designed with a high preload release capability . It opens electronically with up to 500lbs of preload, this allows smooth operation under varying loads on the doors. This overcomes issues such as air pressure, warped doors or stripped seals due to bad weather.

The lock offers lock monitoring and may be fitted to narrow style doors, it also has a holding force of 1500lbs and has been successfully tested on a BS EN 1634-1:2014 fire test for single action doors

For fire rating 1mm Interdens intumescent is encased around the body, behind the forend, and fitted behind the keep.

Features & Benefits

- 1500lbs with 500lbs Preload Holding Force
- Brushed stainless steel finish
- For use with double swing doors or single action doors
- Fail Unlocked (Fail Safe)
- Can be used with narrow frames
- Fire tested to BS EN 1634-1:2014 for 30 & 60 minute timber doors for single action doors
- 500lbs preload
- Lock monitoring
- Mounted horizontally or vertically
- 12V DC and 24V DC options
- Door status monitoring

Certification

Fire Tested: - TRADA Report Number BMT/FEP/F14080 ARI
Dated 19th May 2014 for Single Action Doors
BS EN 1634-1:2014
BS EN 1363-1:2012

RoHS Compliant

CE Marked

AML-350M-PL-12 & AML350M-PL-24 Electric Lock with Preload

Specification	AML-350M-PL-12	AML-350M-PL-24
Operating Voltage	12V DC	24V DC
Voltage Tolerance	±10%	
Current Draw	280mA/12V DC (at Temperature 20°C)	140mA/24V DC (at Temperature 20°C)
Operating Temperature	-10 to 45°C	
Humidity	0~95% Non Condensing	
Lock Bolt Sensor Output	SPDT Rated 3A/125V AC	
Solenoid Testing	Tested to over 250,000 Cycles	
Locking Mode	Fail Unlocked (Fail Safe)	
Backset	30mm	
Net Weight	673g	1380g
Finish	Stainless Steel	

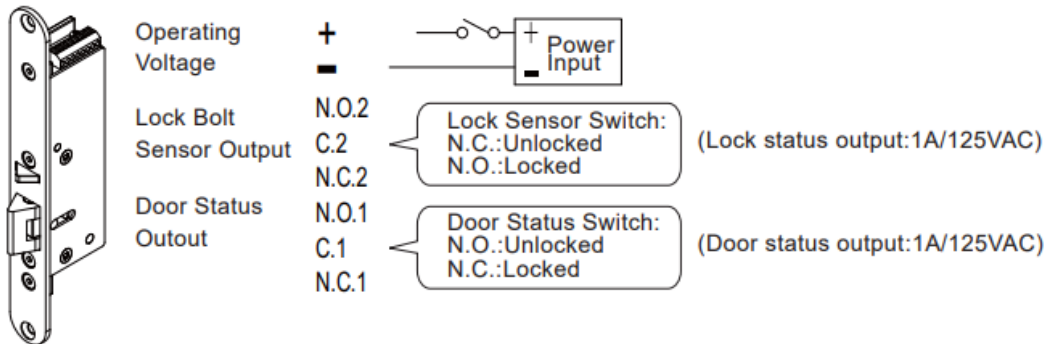
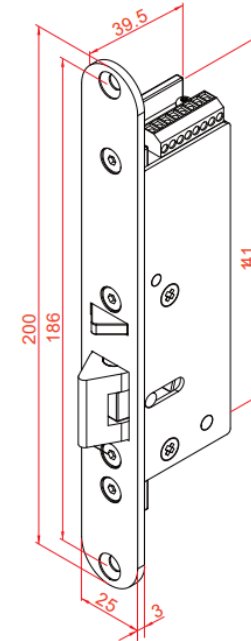

For further information contact:

Securefast plc
 6, The Cedars Business Centre
 Avon Road, Cannock
 Staffordshire
 WS11 1QJ



Call > +44 (0) 1704 502 801

Email > sales@securefast.co.uk

Visit > www.securefast.co.uk