

AMG200 Series 600 lbs Mortice Electro-Magnetic Locks in Transom Housings (Grade 2)

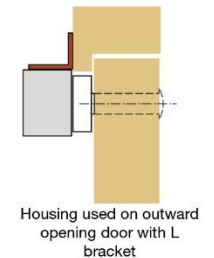

The AMG200 series mortice electro-magnets are designed to offer a clean line across the door transom head or down the side door frame with the magnet encased into the satin anodised aluminium housing.

Securefast Transom Housing has a high holding force of a nominal holding force of 600 lbf per magnet with different voltage options offering a sleek finish suitable for single or double outward door applications.

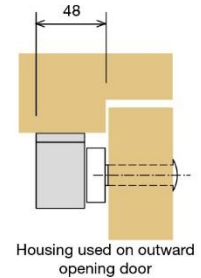
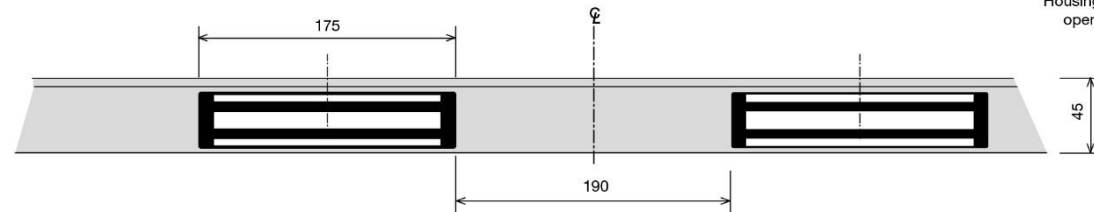
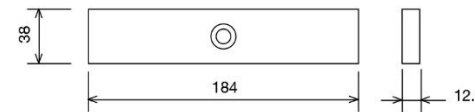
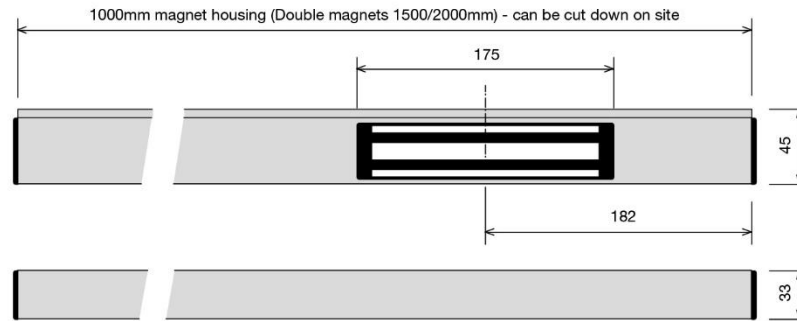

AMG200 Series 600 lbs Mortice Electro-Magnetic Locks in Transom Housings (Grade 2)

Stock Code	Description	Current mA (12/24V)	Application
AMG201/AT	Mortice Magnet (Monitored)	500/250	To suit 200 Series Housings
AMG201/UM	Mortice Magnet (Unmonitored)	500/250	To suit 200 Series Housings
AMG202/AT	1M Transom Housing with 1 Magnet (Monitored)	500/250	Transom Mounting on Single Door
AMG202/UM	1M Transom Housing with 1 Magnet (Unmonitored)	500/250	Transom Mounting on Single Door
AMG203/AT	320mm Transom Housing with 1 Magnet (Monitored)	500/250	Transom Mounting on Single Door
AMG203/UM	320mm Transom Housing with 1 Magnet (Unmonitored)	500/250	Transom Mounting on Single Door
AMG204/AT	1.5m Transom Housing with 2 Magnets (Monitored)	1000/500	Transom Mounting on Double Door
AMG204/UM	1.5m Transom Housing with 2 Magnets (Unmonitored)	1000/500	Transom Mounting on Double Door
AMG205/AT	2m Vertical Housing with 2 Magnets (Monitored)	1000/500	Vertical Mounting on Single Door
AMG205/UM	2m Vertical Housing with 2 Magnets (Unmonitored)	1000/500	Vertical Mounting on Single Door
AMG206/AT	2m Transom Housing with 1 Magnet (Monitored)	500/250	Transom Mounting on Double Door with 1 Leaf Bolted Top & Bottom
AMG207/AT	2m Transom Housing with 2 Magnets (Monitored)	1000/500	Transom Mounting on Double Door
AMG207/UM	2m Transom Housing with 2 Magnets (Unmonitored)	1000/500	Transom Mounting on Double Door

Brackets			
AMH592/L1	1m Transom L Bracket for AMG202 or suits AMG206/AMG207 (Using 2 Brackets per Magnet)		Allows Transom Housing to be Fixed to Shallow Header
AMH592/L2	2m Vertical L Bracket for AMG205/AT or AMG205/UM only		
AMH592/L320	320mm L Bracket for AMG203 Transom Housing		

Features & Benefits

- 12/24V DC (Adjustable)
- To suit medium use applications
- Satin anodised aluminium housings
- Kick off pin in the armature plate to overcome any residual magnetism when power is turned off
- Monitored & Unmonitored versions available
- Continuous housings provide improved aesthetics for high quality installations
- Ideal for sliding door applications
- Housings can be cut and altered on site
- Suitable for both single and double door applications
- CE Marked and tested to TS 010 – Grade 2
- Nominal Holding Force up to 600lbs (2660N) (272 kgf)
- Fire rated to EN1634-1 for FD30 and FD60 timber doors. – Report No. WF417165 & 432748 when used with SINAEM1 intumescent sleeve

For further information contact:

Securefast Limited
6, The Cedars Business Centre
Avon Road, Cannock
Staffordshire
WS11 1QJ



Call > +44 (0) 1704 502 801

Email > sales@securefast.co.uk

Visit > www.securefast.co.uk